



## Set Up Instructions for Gen II Series Gear Sets

18-6350	1.62/2.0:1 RATIO
18-6351	1.47:1 RATIO
18-6352	1.94/2.4:1 RATIO
18-6353	1.81:1 RATIO

### AND BEARING SET W/SPACER 18-1182

COVERING DRIVESHAFT HOUSINGS  
IN SERIAL# RANGE  
OL 100009 AND HIGHER

#### INSTALLERS PLEASE MAKE NOTE

Please turn this Product Information Sheet to owner for future reference, after completing installation.

**PLEASE MAKE NOTE:** The newer Gen II Series Sterndrive Units discontinued use of the cone spacer between the bearings, to set bearing preload on the u-joint assembly, beginning in serial range OL 100009 and higher. This instruction sheet will guide you through the new procedure for establishing and adjusting preload.

The new drive gear bearing carrier has changed to a larger OD of 82.9mm (3,265 inches).

1) Press the bearing cup (race) into the thinner side of the spacer cup. You should see a small shoulder at the bottom if the correct side is if facing up. Press bearing cup until it bottoms out on the shoulder.

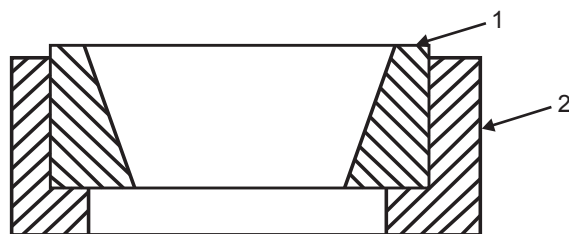
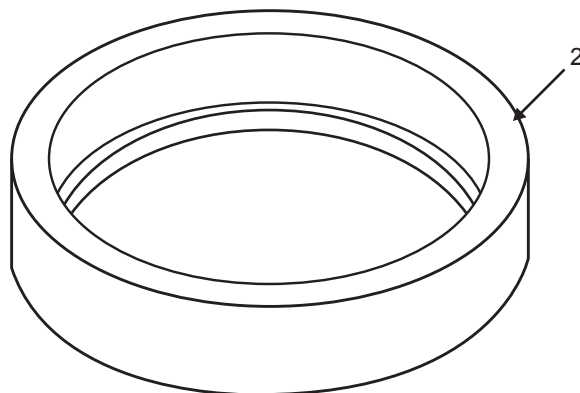
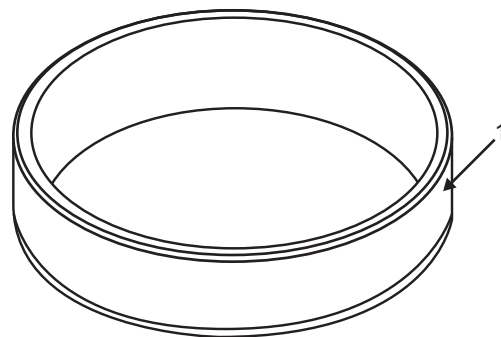

1...Cup, Bearing  
2...Cup, Spacer

2) Press the bearing cone onto the pinion gear until it seats fully against the back side of the gear, using tool number 18-9865.

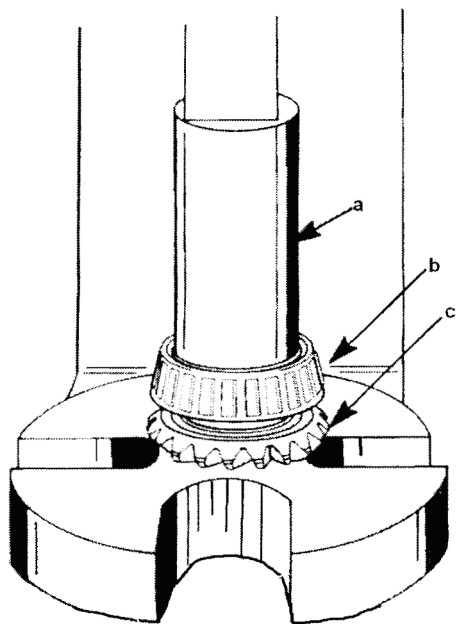

a...Shows requirement of pushing against suitable mandrel to install inner bearing cone.  
 b...Shows bearing cone.  
 c...Shows pinion gear as it rests on mandrel.

- 3) Place the loose bearing race over the bearing cone that was just installed.
- 4) Place the bearing race that was pressed into the spacer onto this bearing race (race side facing up).
- 5) Press the remaining bearing cone onto the pinion gear, stopping just at the point where the bearing starts.

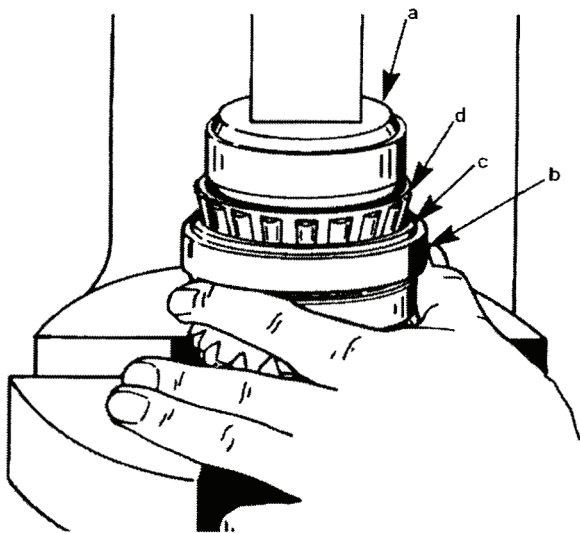

a...Identifies pushing against bearing cone's inner shoulder, while gear is setting on suitable mandrel.  
 b...Identifies spacer that must remain free moving once last bearing cone is installed.  
 c...Identifies bearing race pressed into spacer.  
 d...Identifies bearing cone.

6) Following the diagram shown below, assemble the u-joint/gear assembly.

\*) In the following order...assemble retainer ring, thrust washer, o-ring and finally the oil seal carrier. Proceed from there with assembling the gear/bearing assembly, washer, then self-locking nut. The nut should only go on finger tight.

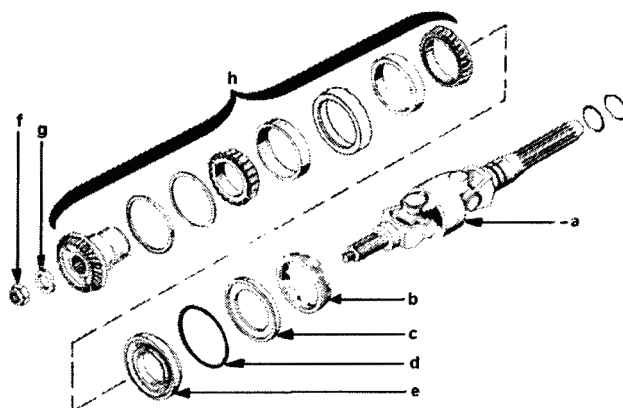

a...Identifies the u-joint assembly  
 b...Identifies the retaining castle nut  
 c...Identifies the thrust washer  
 d...Identifies the o-ring  
 e...Identifies the oil seal carrier  
 f...Identifies the self-locking nut  
 g...Identifies the compression washer  
 h...Identifies the gear/bearing assembly

6b...Secure the u-joint retainer tool in an appropriate vise and place the u-joint assembly into the retainer tool.

c...Locate a screwdriver or steel rod capable of passing through the connector/u-joint assembled yolks. This will prevent the assembly from rotating as you tighten the self-locking pinion nut. Just tighten the nut till tension is met. Continue to insert the retaining rod and applying short strokes of tension to the lock nut until preload tension is met.

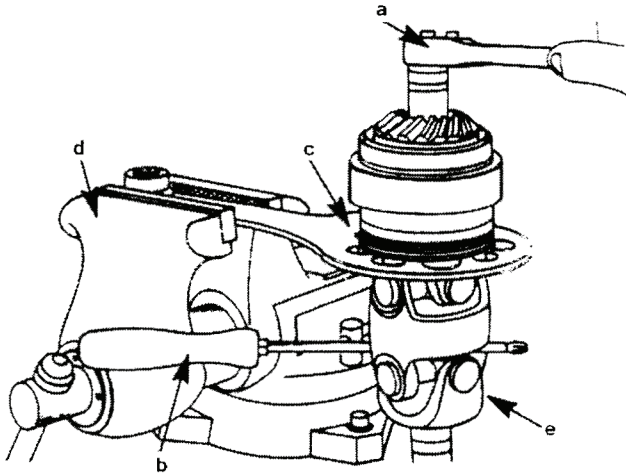

- a...Identifies ratchet wrench with socket
- b...Identifies item needed to use as rotation control
- c...Identifies u-joint retainer tool (18-9803)
- d...Identifies appropriate vise to use
- e...Identifies u-joint assembly

7) Bearing preload is achieved by replacing the ratchet with an inch/pound reading torque wrench, to start. Grasp the outer surface of the bearings with one hand, locating the assembly in the center of the retaining tool. Slowly use the torque wrench to turn the pinion nut while holding the outer bearing surface with your free hand. After rotating the assembly at least three revolutions, read the torque wrench as you pass around on a slow turn. You must obtain a "rolling torque" of 6 to 10in. lbs (.7-1.1 N.m.). If reading is less, insert retaining rod and tighten nut slightly. Rotate again, as before, and take a reading. If torque reading is correct, assembly can be installed. If reading is still not enough, repeat tightening sequence in short bursts until correct rolling resistive torque is achieved.

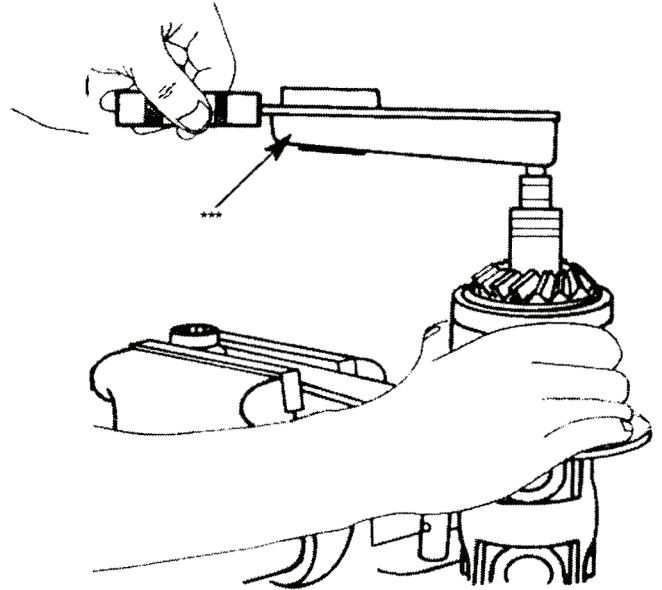

\*\*\*...inch/pound reading torque wrench

**WARNING:** If you are aggressive in tightening the pinion nut and exceed the 10in. lb. resistive rolling torque specification, the entire bearing assembly will have to be removed and you will have to start all over. Leaving it at too tight of a resistive torque can cause premature bearing failure and void the warranty.